

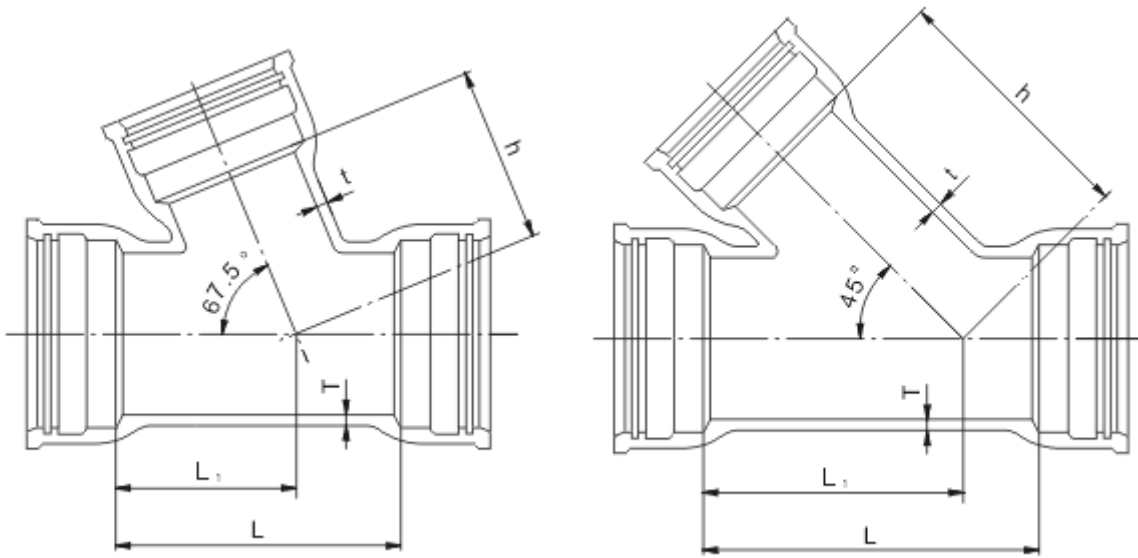

●All Socket Angle Branch



Unit : mm

67.5°								45°							
DN		Thickness		Dimension			Weight (kg)	DN		Thickness		Dimension			Weight (kg)
D	d	T	t	L	L <sub>1</sub>	h		D	d	T	t	L	L <sub>1</sub>	h	
150	100	7.8	7.2	356	213	228	32.5	150	100	7.8	7.2	515	445	445	40.1
	150	7.8	7.8	413	241	241	38.7		150	7.8	7.8	585	480	480	49.5
200	100	8.4	7.2	356	223	254	44.1	200	100	8.4	7.2	534	490	490	54.4
	150	8.4	7.8	413	252	269	50.7		150	8.4	7.8	605	525	525	64.1
200	200	8.4	8.4	484	287	287	60.4	200	200	8.4	8.4	676	560	560	77.5
	250	150	9.0	7.8	413	262	62.7		250	150	9.0	7.8	624	570	570
250	200	9.0	8.4	484	298	315	72.9	250	200	9.0	8.4	695	605	605	93.2
	250	9.0	9.0	549	331	331	83.7		250	9.0	9.0	767	640	640	109.2
300	150	9.6	7.8	451	293	324	74.5	300	150	9.6	7.8	653	605	605	91.9
	200	9.6	8.4	523	328	343	86.3		200	9.6	8.4	725	640	640	108.5
350	250	9.6	9.0	588	361	359	97.6	350	250	9.6	9.0	801	680	680	125.2
	200	10.2	8.4	533	344	371	109.0		200	10.2	8.4	744	680	680	134.9
400	250	10.2	9.0	599	377	386	120.9	400	250	10.2	9.0	815	715	715	151.3
	200	10.8	8.4	533	354	399	124.1		200	10.8	8.4	763	725	725	155.4
450	250	10.8	9.0	599	387	414	136.7	450	250	10.8	9.0	830	755	755	171.9
	200	11.4	8.4	543	370	426	145.0		200	11.4	8.4	788	770	770	182.4
500	250	11.4	9.0	608	403	442	158.4	500	250	11.4	9.0	859	805	805	200.4
	200	12.0	8.4	543	381	454	165.5		200	12.0	8.4	802	810	810	209.5
	250	12.0	9.0	608	414	470	179.9		250	12.0	9.0	865	835	835	226.9